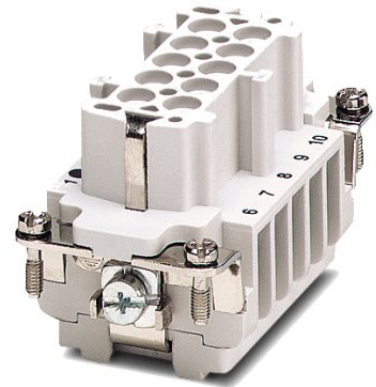

## HC-B 10-EBUS

Order No.: 1771202

<http://eshop.phoenixcontact.de/phoenix/treeViewClick.do?UID=1771202>

HEAVYCON female insert, B10 series, 10-pos., screw connection

**Commercial data**

EAN	4017918035945
Pack	10 Pcs.
Customs tariff	85366990
Weight/Piece	0.0812 KG
Catalog page information	Page 345 (PC-2007)

**Product notes**WEEE/RoHS-compliant since:  
01/31/2006

<http://www.download.phoenixcontact.com>  
Please note that the data given here has been taken from the online catalog. For comprehensive information and data, please refer to the user documentation. The General Terms and Conditions of Use apply to Internet downloads.

**Technical data****General data**

Note	For housing HC-B10
Connection systems	Screw connection
Tightening torque	0.5 Nm
Ambient temperature (operation)	-40 °C ... 125 °C (including heating up of contacts)
Pollution degree	3

Surge voltage category	III
Test voltage	3 kV AC
Constructional and testing regulations	DIN VDE 0627/86
	DIN VDE 0110/02.79
	DIN VDE 0110-1/04.97
	IEC 60664-1, DIN IEC 60512
	IEC 60352
Number of positions	10
Insertion/withdrawal cycles	≥ 500
Design	B10
Connection in acc. with standard	IEC / EN
Conductor cross section	0.5 mm <sup>2</sup> ... 2.5 mm <sup>2</sup>
Connection cross section AWG	20 ... 14
Stripping length of the individual wire	7 mm

**Material data**

Inflammability class acc. to UL 94	V0
Contact material	Copper alloy
Contact surface material	Ag
Contact carrier material	PA

**Electrical characteristics**

Rated voltage (III/3)	500 V
Rated surge voltage	6 kV
Rated current	16 A

**Certificates / Approvals**



**CSA**

Nominal voltage U <sub>N</sub>	600 V
Nominal current I <sub>N</sub>	16 A
AWG/kcmil	20-14

**UL**

Nominal voltage $U_N$	600 V
Nominal current $I_N$	15 A
AWG/kcmil	18-12
Certification	CSA, GOST, UL

**Accessories**

Item	Designation	Description
<b>General</b>		
1604997	HC-B-PES	Additional PE screw, for contact inserts HC-B / HC-BB / HC-DD / HC-D40 / HC-D64

**Drawings**

Diagram

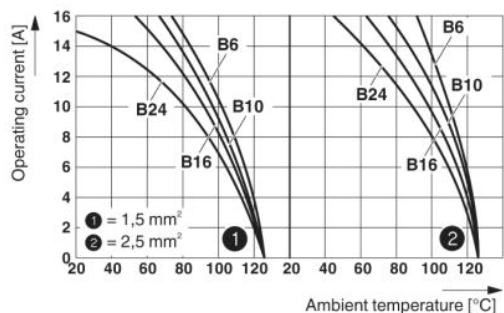

Dimensioned drawing

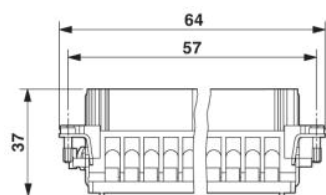

Female insert

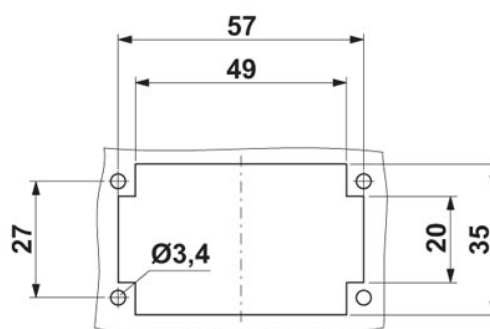
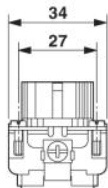

Panel cutout

Schematic diagram

---

